



# PERSHING COUNTY BUILDING DEPARTMENT BUILDING GUIDE

## Single Family Residential Detached Garage

### Building Guide

#### Directions

1. Complete this Building Guide by filling in the blanks on page two and three, indicating which construction details will be used below.
2. Provide a floor plan (site plan) showing dimensions of your project or addition and its relationship to existing buildings or structures on the property, and the distance to existing property lines.
3. Fill out a building permit application.

The majority of permit applications are processed with little delay. The submitted documents will help determine if the project is in compliance with building safety codes, zoning ordinances, and other applicable laws.

### Foundation Details

#### Foundation Detail A

Note: Check with Building Department for swelling soils. Cassons may be required

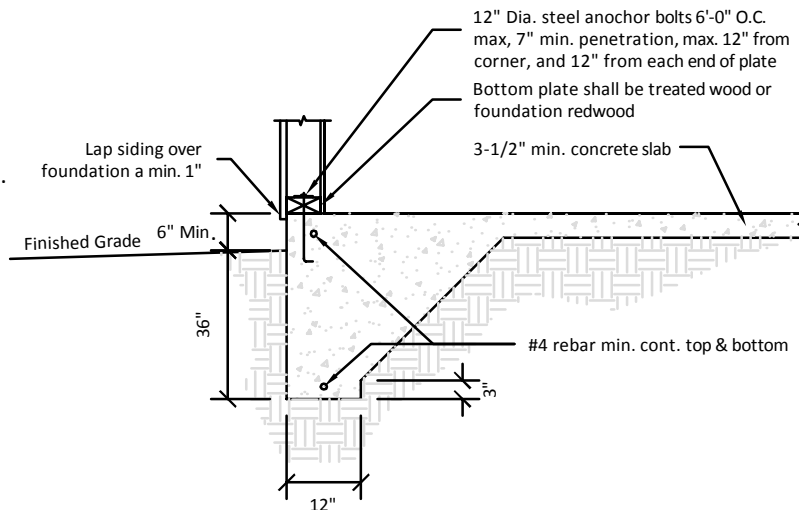

#### Foundation Detail B

Note: Check with Building Department for swelling soils. Cassons may be required

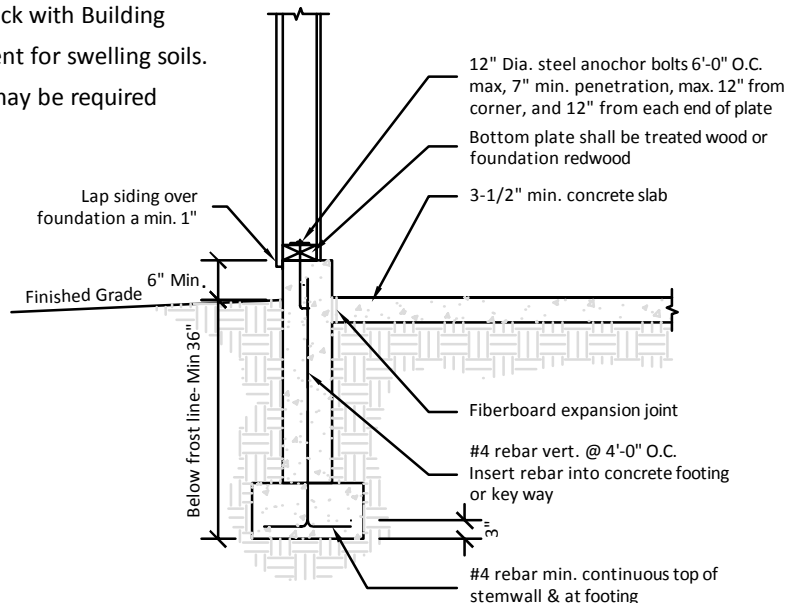



**PERSHING COUNTY BUILDING  
DEPARTMENT BUILDING GUIDE**

# Single Family Residential Detached Garage

## Floor Plan

Property Address \_\_\_\_\_

Permit# \_\_\_\_\_

### Directions

1. Fill in the blanks on pages two and three with dimension and materials which will be used to build the structure. Please print legibly.
2. Show door and window header sizes and location.
3. Show size of landing in front of door(s).
4. Indicate in the check boxes on page three which detail from page 4 will be used.

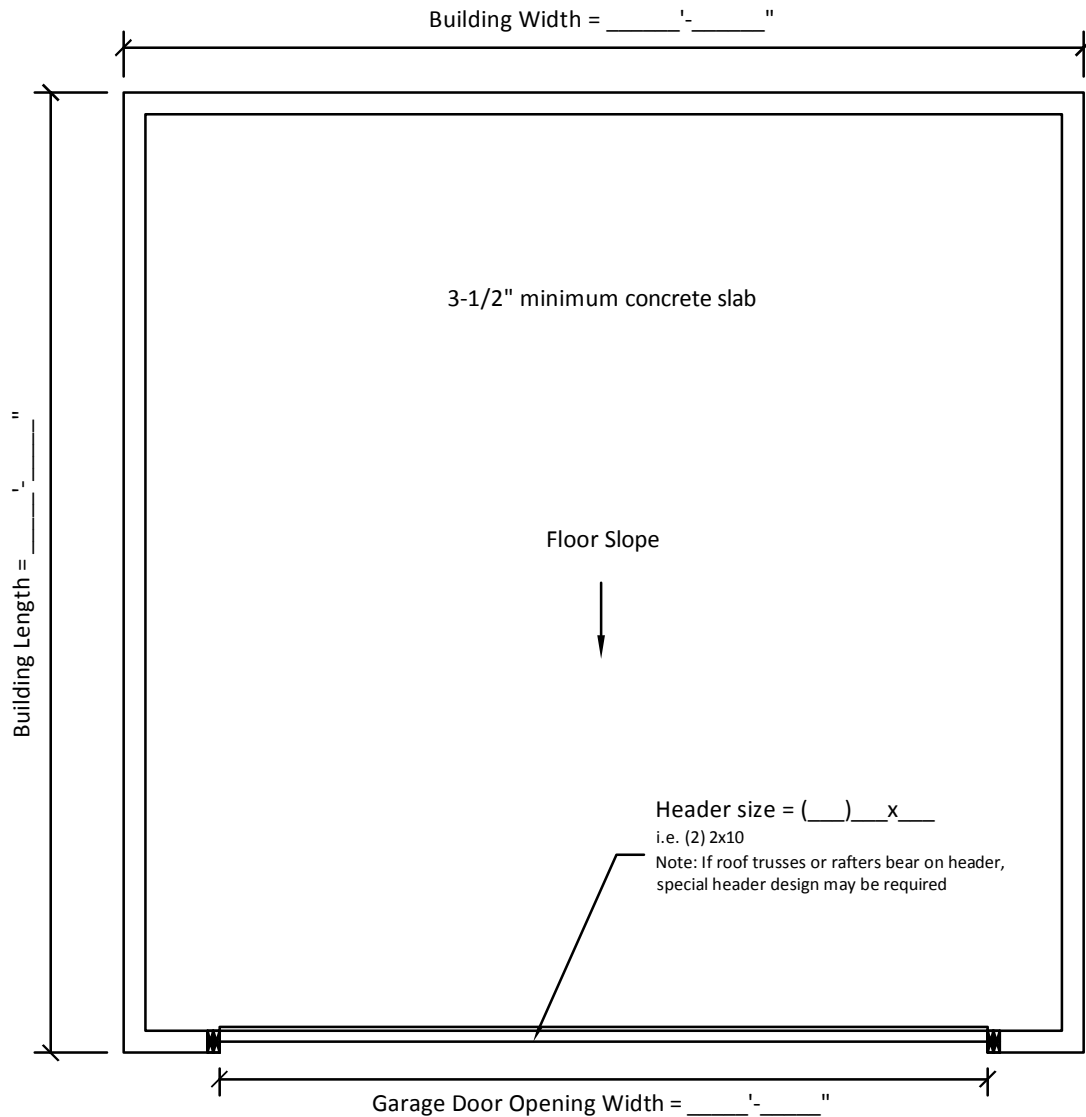



# PERSHING COUNTY BUILDING DEPARTMENT BUILDING GUIDE

## Single Family Residential Detached Garage

### Building Section

Property Address \_\_\_\_\_  
Permit# \_\_\_\_\_

Note: Roof not to exceed 24'-0" span

### Inspections

Please contact the Pershing County Building Department to have the following phases of construction inspected:

1. Rough in of footings prior to concrete work. \_\_\_\_\_  
Insp. Date \_\_\_\_\_
2. Framing and structural work prior to cladding. \_\_\_\_\_  
Insp. Date \_\_\_\_\_
3. Insulation, Mechanical, Electrical Plumbing rough. \_\_\_\_\_  
Insp. Date \_\_\_\_\_
4. Finish and Final on work and Utilities. \_\_\_\_\_  
Insp. Date \_\_\_\_\_

