



PERSHING COUNTY BUILDING DEPARTMENT BUILDING GUIDE

Single Family Residential Patio Covers & Carports

Building Guide

Directions

1. Complete this guide by filling in the blanks with dimension and materials which will be used to build the structure. Please print legibly.
2. Indicate in the check boxes which details from page 2 will be used. Please note if any of the sides of your carport addition are closer than 3'-0" to the property line, then the side of the carport must be enclosed with a solid 1-hour, fire-rated wall as shown in Alternate Details B & C. You must, however, keep at least two sides of the carport open to conform to the building code requirements. A zoning variance may be required.
3. Fill out a building application form and attached these construction details.

Project Address: _____

Patio Section

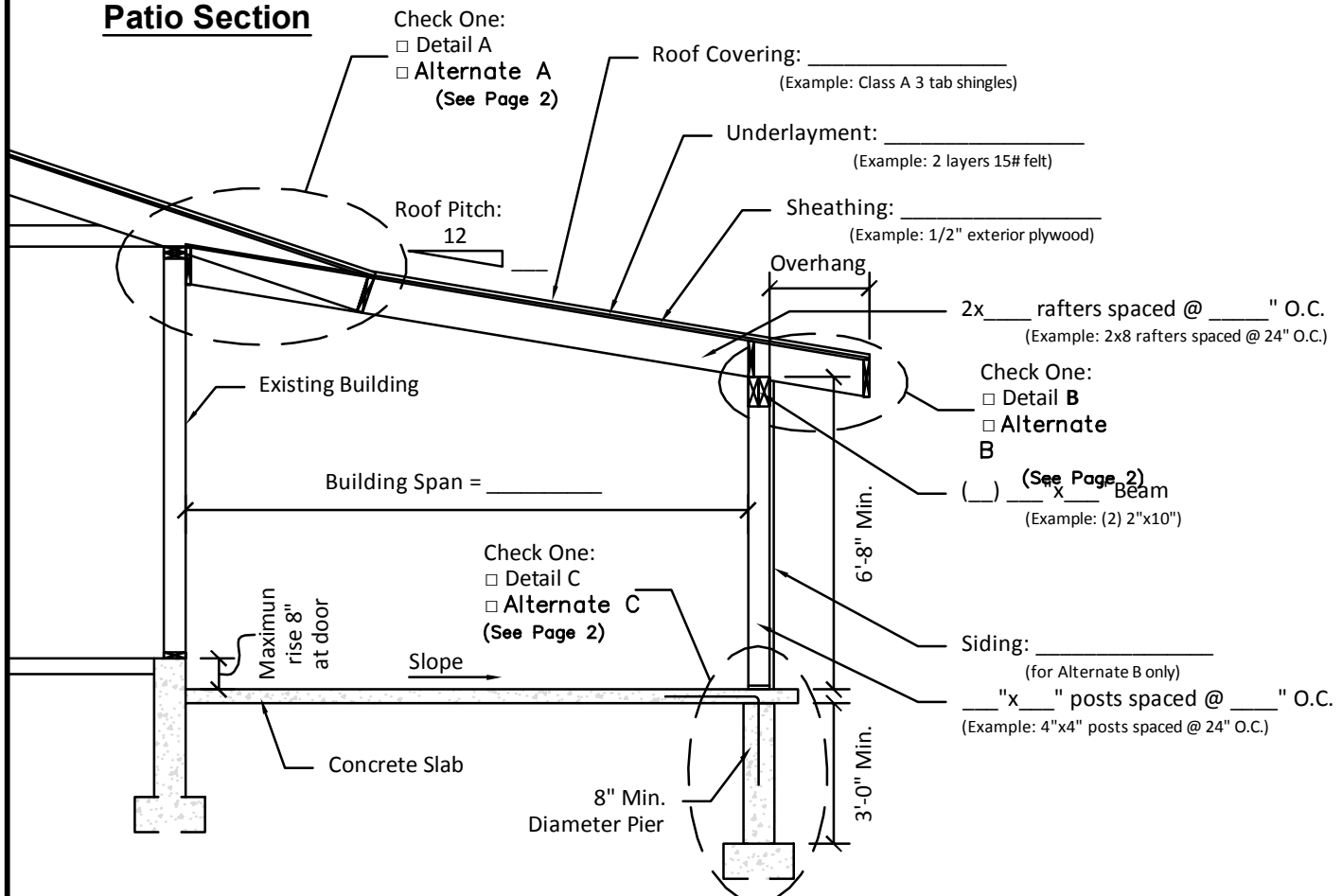



PERSHING COUNTY BUILDING DEPARTMENT BUILDING GUIDE

Single Family Residential Patio Covers & Carports

Detail A

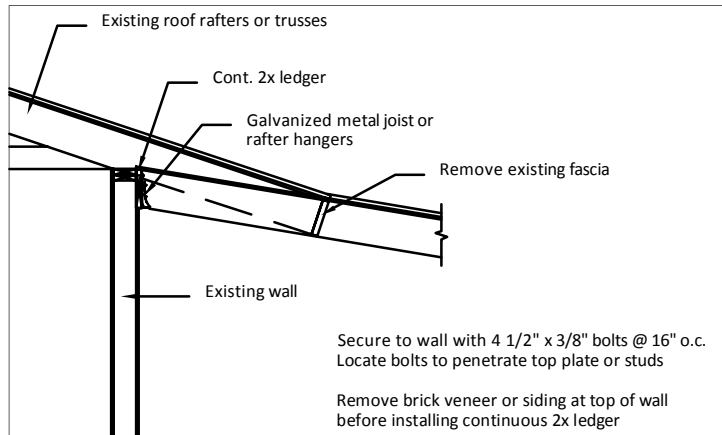

Alternate Detail A

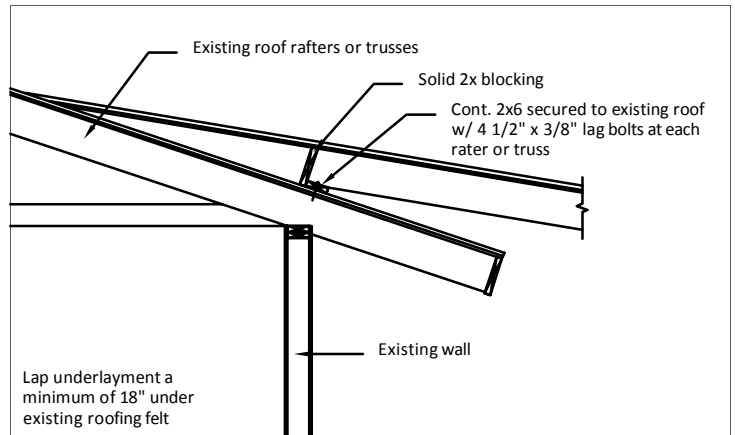

Detail B

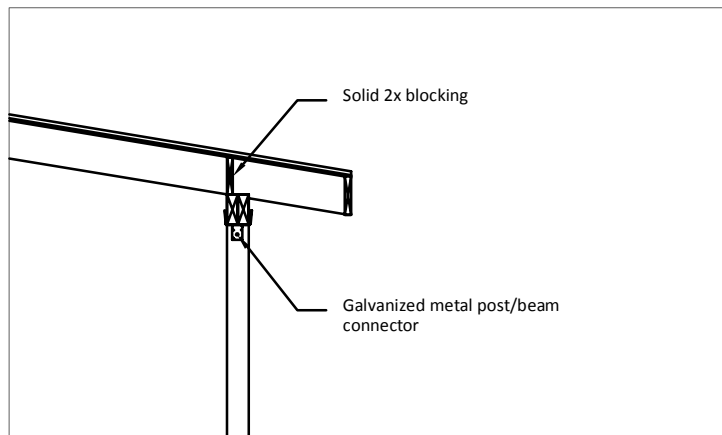

Alternative Detail B - One Hour Wall

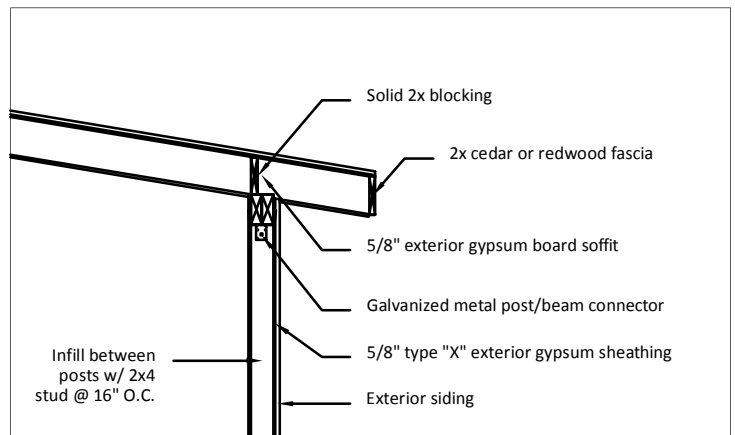

Detail C

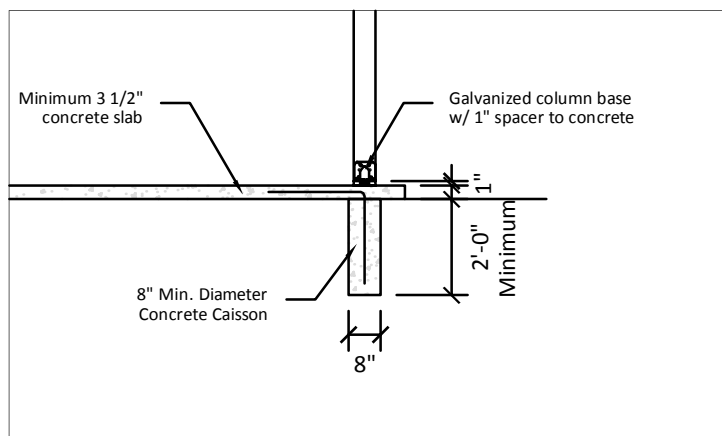

Alternate Detail C - One Hour Wall

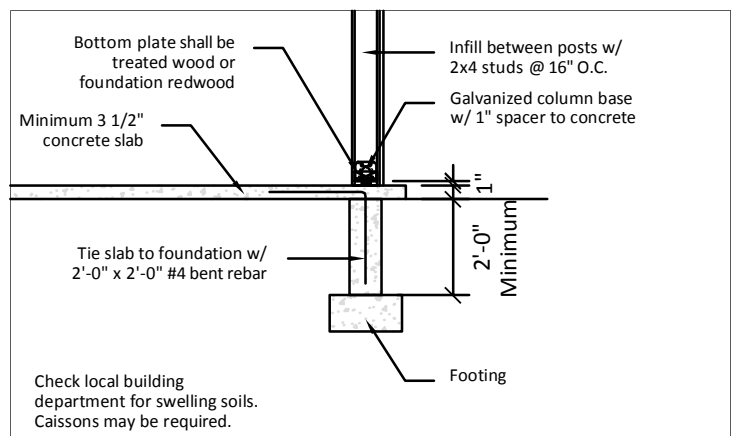



PERSHING COUNTY BUILDING
DEPARTMENT BUILDING GUIDE

Single Family Residential Patio Covers & Carports

Patio Floor Plan

Directions

1. Draw the floor plan in the area provided above. Indicate North arrow, the outside dimensions in all directions, and location of existing structures and set backs. Show all inground and above ground utilities within 25' of the new structure.

Project Address: _____

Inspections

Please contact the Pershing County Building Department to have the following phases of construction inspected:

1. Rough in of footings prior to concrete work. _____
Insp. Date
2. Framing and structural work prior to cladding. _____
Insp. Date